

This document describes the arbitration policies in effect for all Simulcast, Online Event Sale and OVE.com transactions executed through a remote bid purchase. These policies attempt to mirror the in-lane arbitration policy with exceptions made for the online marketplace.

I. General Arbitration Policies

1. The sales through online channels are intended to promote fair and ethical treatment to both the Buyer and Seller. If the Auction determines that the transaction is not fair and ethical to either party, the Seller and Buyer agree that the Auction may cancel the sale, at its sole discretion.
2. The Auction makes no representations or guarantees as to the description, equipment, history, warranties, service policy, title status/accuracy or odometer on any vehicle sold or offered for sale. The Auction does not guarantee or get involved in any factory or dealer warranty coverage issues on vehicles sold or offered for sale on Online.
3. The decisions of the Arbitration Department are final and binding on both the Buyer and Seller. The Auction reserves the right to assess an arbitration fee to the Buyer if an arbitrated claim is deemed to be not valid or too frivolous. Any arbitration must be properly documented in writing and signed by the arbitrator. If the arbitration is valid, the Auction reserves the right to assess an arbitration fee to the Seller if they knowingly omitted an announcement. This fee is in addition to any charges associated with the arbitration procedure; such as check out fees at a specialty shop or transportation costs to and from a garage, etc.
4. The Auction is not a party to the contract of the sale. The sales contract is between the Seller and Buyer only. United States Sellers are required to give the Federal Odometer Mileage Statement in connection with any Auction sale as required by the Motor Vehicle Information and Cost Savings Act of 1972 as amended or other applicable laws. The Auction is not responsible and does not guarantee the accuracy of odometer readings, odometer statements, or damage disclosure statements.
5. Any vehicle sold "AS-IS" is NOT subject to mechanical or cosmetic arbitration.
6. All vehicles consigned must have a public Vehicle Identification Number (VIN) plate attached to the vehicle. Those vehicles having a reassigned VIN plate by the [state, province or other governing locality](#) in place of the original VIN plate must be announced or will be subject to sale cancellation or Buyer return. The Auction reserves the right to refuse the sale of any vehicle in which the VIN plate appears altered in any way.
7. The Auction reserves the right to review any audio/video or online vehicle listing documentation for verifying accuracy of a transaction.
8. All guarantees as stated by the Seller are those of the Seller only. The Auction does not make any guarantees, expressed or implied. The Auction assumes no responsibility for vehicle record books, service records, warranty vehicles, or history.

9. The Auction does not guarantee information listed in Electronic Data Vehicle Histories (i.e. CarFax, AutoCheck, etc.) and may not arbitrate solely on EDVH data.
10. The Auction does not guarantee any warranty books, VIN-plates, or the year of kit vehicles, trailers, motorcycles, watercraft, recreational vehicles, antique, homemade or modified vehicles. All of these vehicles are sold "AS-IS" and have no odometer or frame guarantee. The Auction does not guarantee titles on watercraft.
11. The Auction reserves the right to reject any vehicle that management judges to be unsafe.
12. Engines/Rear End – No arbitration on noises that are inherent or typical to a particular model or manufacturer, unless deemed "excessive" by the arbitrator on non-warranty items.
13. Standard transmissions cannot be arbitrated for manual clutches unless completely inoperative.
14. All arbitration must be initiated within 2 days of Buying dealer's verified receipt of the vehicle, not to exceed 10 days from purchase (purchase of a Post Sale Inspection (PSI) may increase arbitration timeframes of items covered in the PSI). It is the Auction's responsibility to inform the Seller of any pending PSI or arbitration resulting from the sale.
15. Manufacturer's Warranty: The availability of a manufacturer's warranty shall not affect a Buyer's right to arbitrate a vehicle.
16. The arbitrator will inspect only the defect(s) which are on the arbitration form. Each vehicle is allowed one chance at mechanical/ cosmetic arbitration. If price adjustment is made and accepted, vehicle becomes "AS-IS", property of Buyer, and is not subject to any further arbitration for mechanical defects or adjustments. The decision of the arbitrator is final, and binding to both Buyer and Seller.

II. Sale-Light System – Simulcast Only

1. The NAAA has a standardized light system to describe the condition and/or announcements related to the vehicle being sold. The light system is defined as:
 - I. Green Light – "Ride & Drive": The green light signals that this vehicle is guaranteed under the conditions outlined in the Arbitration timeframe and As-Is Arbitration section, except for specific announcements made prior to the sale.
 - II. Yellow Light – "Announcements": This light is an indication to the Buyer that the Auctioneer or Selling Representative has made announcements that qualify the condition and limit arbitration of this vehicle.
 - III. Red Light – "As-Is": Vehicles selling under the red light will only qualify for arbitration under the rules outlined in the Arbitration timeframe and As-Is Arbitration section.
 - IV. Blue Light – "Title Attached/Title Unavailable/Title Absent": This light is used to announce that the title is not present at the time of sale. For Auction rules regarding titles, please refer to the Title Arbitration Policy section. If T/A is not announced, a vehicle could be arbitrated for misrepresentation.

2. The Seller understands that the sale lights are a binding representation of vehicle condition, and is therefore responsible for ensuring that their vehicles sell under the correct light in the lane.
3. The Buyer is responsible for listening to announcements related to the vehicle, made by the auctioneer or Selling Representative, prior to the start of the sale for each vehicle. The Buyer is also responsible to observe and understand the sale lights (Green, Yellow, Red and Blue), which identify various sale conditions for the vehicle

III. Seller Responsibilities

1. Seller will be held responsible for the accuracy and completeness of all descriptions of vehicles they offer for sale online including all images, text and verbal representations made by Seller, designee or Seller's agent including 3rd party condition reports or vehicle listing agents at the time of sale. This includes year, make, model, odometer reading, equipment, announced conditions, and any defect or damage that is "visible" in nature. Examples of these mandatory disclosures include, but are not limited to: paintwork, dents, scratches, tire conditions, mismatched tires, interior damage and inoperable accessories. The Seller must disclose damage with an auction (wholesale) repair cost in excess of \$500. Undisclosed damage in excess of \$500 can be arbitrated by the buyer due to an inadequate disclosure of damage or condition. Actual images of the listed vehicle must be used unless proper disclosure is noted by the Seller which makes it clear the actual vehicle is Not Shown.
2. Odometer announcements are required on all vehicles. Any statement made by the Seller and all known odometer discrepancies are grounds for arbitration.
3. The Seller is responsible for reimbursement of all reasonable documented expenses incurred by the Buyer (excluding profit, commissions and detail charges) on vehicles arbitrated for unannounced conditions. Expense reimbursements will be at the sole discretion of the Auction and will at times be limited to reasonable and documented expenses and transportation only.
4. The Seller has the responsibility to announce any known state, province or other governing locality fees, taxes or other fees over \$100 due on the vehicle.
5. Title Discrepancies must be announced including disclosure requirements [if required by state, province or other governing locality] (i.e. 25%), previous salvage, theft recovery, not actual miles (previously TMU), odometer replacements, flood/fire history and Lemon Law buybacks.
6. All titles submitted must be in the Seller's name. It is the Seller's responsibility to ensure that a sold vehicle's title is **negotiable in the state, province or other governing locality in which the Auction resides** and that the title is clear of all liens and encumbrances. **[Note: All titles must be in the Seller's name or reassigned to the seller, and negotiable in the state the vehicle is sold.]**
7. Seller is responsible for correct VIN numbers on titles and vehicles. All vehicles sold through the Auction are subject to inspection by the FBI, State Police, National Auto Theft Bureau, and Local Police Authorities and/ or any other applicable government authority.

8. Seller shall be solely responsible for repurchase of any vehicle sold through the Auction found to be stolen prior to the date of sale.
9. Seller has the responsibility to produce a negotiable/ marketable title to the the Auction within a maximum number days defined in auction Title Policy (Auction Choice) of the date of sale [sale day is day one (1)], or as specified by state law, provincial law or other regulation on vehicles sold "Title Attached" (no title present at time of sale). Refer to local Auction Policies for days allowed on vehicles sold with Title Attached. If a vehicle is sold with "Title Attached" or "Title Unavailable" but is not announced as such, the vehicle can be arbitrated for misrepresentation.
10. All multipurpose and utility-type vehicles are assumed to be 4x2 unless otherwise announced. However, if a 4x2 multipurpose, utility-type vehicle or pickup has been altered in appearance or stance to resemble a 4x4, a 4x2 announcement will be required.
11. Seller must announce previously voided OEM warranties on vehicles within OEM mileage/age warranty limits
12. See mandatory Seller Disclosure Requirements on the matrix below:

NAAA Seller Disclosure Requirements or can be arbitrated	Green Light	Red Light
	R/D	As-Is
Issues		
Frame Damage, altered, or repaired Frame Damage per NAAA Policy	Yes	Yes
Unibody Damage, altered, or repaired Unibody Damage per NAAA Policy	Yes	Yes
Transmission problem*	Yes	No
Upper Engine problem*	Yes	No
Lower Engine Problem (Below Heads)	Yes	No
Sludged Engine	Yes	No
Cracked or repaired Block	Yes	No
4X4 system is inoperable*	Yes	No
ABS problem*	Yes	No
SRS-absence of or problems with (airbags)*	Yes	No

Emission control equipment missing, or inoperable*	Yes	No
Air Conditioning compressor engagement*	Yes	No
Mechanical/Electrical Problems*	Yes	No
Vehicles without Air Conditioning -calendar year models or newer (not equipped)	Yes	No
Unannounced Voided Factory Warranty	Yes	No
<i>Historical-Non-Visible Issues</i>		
Taxis, Police Cars, Government vehicles that are Calendar year and up to 4 years old	Yes	Yes
Flood Damage	Yes	Yes
Fuel Conversion	Yes	No
Lemon-Law/Manufacturer's Buyback	Yes	Yes
Logo or decal misrepresentation	Yes	Yes
Non-original engine (excludes items replaced under manufacturer warranty up to 4 years)	Yes	No
Not Actual Miles (previously TMU) or Inoperative odometer	Yes	Yes
Paintwork **	Yes	No
Previously Imported vehicles that are Calendar year and up to 4 years old***	Yes	Yes
Salvage or Reconstructed (Including theft recovery history)	Yes	Yes
State, providence or other governing locality -issued VIN plates (reassigned public VINs) including kit vehicles	Yes	Yes
Gray Market Vehicles – As defined in Section VI & VII	Yes	Yes
Vehicles being sold with a Certificate of Origin (CO), Manufactures Statement of Origin (MSO), Insurance and/or Salvage titles (including history) or repo affidavit title (if required by state, providence or other governing locality law)	Yes	Yes

Vehicles being sold with no title (Bill of Sale only)	Yes	Yes
Bio-Hazard Vehicles (both cleaned and contaminated)	Yes	Yes
Unannounced previously voided warranty	Yes	No
Any state, providence or other governing locality required damage disclosure	Yes	Yes
Online Arbitratable Issues		
Glass damage	Yes	No
Hail damage	Yes	No
Tire problems	Yes	No
Upholstery problems	Yes	No
Visible Body Damage	Yes	No
*Must announce defects that are \$500 or more to repair **Bumpers are not included ***Unless state, provincial or local law supersedes		

IV. Buyer Responsibilities

As to any vehicle purchased on online, the Buyer is responsible for the following:

1. The Buyer or Buyer's agent (transporter or driver) should note any obvious damage on the gate release prior to removing the vehicle from the Auction location
2. Buyer will inspect the vehicle immediately upon receipt at Buyer's location. The Buyer must verify the Seller's representations and notify the Auction immediately of any discrepancies within the time frame as stated in this arbitration policy. Buyer will verify odometer reading upon arrival at Buyer's location. Mileage must be the same as it was when purchased if arbitrating for inoperable odometer.
3. The Buyer is responsible for understanding the online Bidding/Proxy Bidding and Buy Now procedures associated with online buying.
4. The Buyer will inform the Auction immediately of any discrepancies as to Seller's representations, warranties, and descriptions. Arbitration will be limited to the specific defects described by the Buyer upon placing the vehicle in arbitration.
5. Buyer guarantees sufficient funds are available and will remain on deposit at Buyer's bank to cover all checks and drafts. Until payment and receipt of title, the Buyer shall acquire neither title to the vehicle nor any right to sell or offer for sale.

6. Buyer will pay the bid price plus applicable fees and draft fees (if applicable). Payment means must be established day of sale. Floor plan payments must be established on day of sale.
7. Buyer agrees to be liable for any and all work done to a vehicle prior to returning the vehicle to the Auction except on vehicles arbitrated for unannounced conditions not detectable through vehicle inspection (i.e. stolen vehicle, odometer, title discrepancy - does not include title unavailable).
8. Buyers should thoroughly check and test drive every vehicle. If there is any problem, a complaint must be properly filed with the Arbitration Office of the Auction within the established arbitration time limit. The Buyer assumes responsibility for mechanical failure once the arbitration period is over.
9. It is the Buyer's responsibility to review all images and understand all announced conditions, descriptions and condition data before placing bids/Buy Now. Once the vehicle is sold the Buyer should review the Purchase Confirmation for completeness. The Auction will not arbitrate for defects visible in the digital images or items listed in the descriptions, condition data or announced conditions Online.
10. Mileage, model, and other information written on the window of sale vehicles, in Auction Catalogs or verbally conveyed by the Seller is for the convenience of the Buyer and is not to be relied upon as accurate or complete. Buyers should satisfy themselves as to year, mileage, model type, and/or equipment by viewing the listing or contacting the Auction prior to bidding. The Auction will not arbitrate vehicles based on incorrect information written on a vehicle or in the catalog.
11. The Buyer is responsible for any pending sale from arbitration. Many auctions locations offer Pre-Sale Inspections as a service to inspect vehicles prior to purchase; additionally online Buyers are encouraged to buy a Post Sale Inspection (PSI) on vehicles purchased.

V. Arbitration timeframe and As-Is Arbitration

Vehicles that have any undisclosed damage, conditions, or discrepancies that were not disclosed or announced at the time of the sale must be reported to the Auction within the time frame identified in this policy in order to be eligible for arbitration. Undisclosed damage, with an auction (*repair cost will be determined and posted by the Auction*) repair cost in excess of \$500, may be arbitrated. Vehicles must be returned to the Auction in the same or better condition than when purchased. Expense reimbursements will be at the sole discretion of the Auction and will be limited to reasonable and documented expenses. Lost profit, commissions, floor plan expenses, and etc. will not be reimbursed. All arbitration must be initiated within 2 days of Buying dealer's verified receipt of the vehicle, not to exceed 10 days from purchase. Purchase of a Post Sale Inspection (PSI) may increase arbitration timeframes of items covered in the PSI.

Refer to the matrix below for arbitration time periods for undisclosed defects.

NAAA Seller Disclosure Requirements Time Periods for Buyer Discovery	Arbitration Period	
	Green Light	Red Light
Issue	R/D	As-Is
<i>Driveability Issues</i>		
Transmission problem**	2 Days*	N/A
Engine problem**	2 Days*	N/A
Cracked or repaired Block	2 Days*	N/A
4X4 system is inoperable**	2 Days*	N/A
ABS problem**	2 Days*	N/A
Emission control equipment missing or inoperable**	2 Days*	N/A
Air Conditioning compressor engagement**	2 Days*	N/A
Electrical Problems*	2 Days*	N/A
Vehicles without Air Conditioning -Calendar year or newer (not equipped)	2 Days*	N/A
SRS-absence of or problems with (airbags)**	2 Days*	N/A
Frame Damage, altered, or repaired Frame Damage per NAAA Policy	2 Days*	2 Days*
Unibody Damage, altered, or repaired Unibody Damage per NAAA Policy	2 Days*	2 Days*
<i>Historical-Non-visible Issues</i>		
Logo or decal misrepresentation	2 Days*	2 Days*
Paintwork **	2 Days*	N/A
Not Actual Miles (previously TMU) or inoperative odometer***	2 Days*	2 Days*
Taxis, Police Cars, Government vehicles that are Calendar	2 Days*	2 Days*

year and up to 4 years old		
Flood Damage (By Auction Inspection)	2 Days*	2 Days*
Flood Damage History (Discovered by DMV or Insurance Company Records)	120 Days	120 Days
Fuel Conversion	2 Days*	N/A
Lemon-Law/Manufacturer's Buyback	2 Days*	2 Days*
Non-original engine (excludes items replaced under manufacturer warranty) Calendar year and up to 4 years old	2 Days*	N/A
Unannounced voided factory warranty	2 Days*	N/A
Previous imported vehicles that are Calendar year and up to 4 years old	2 Days*	2 Days*
Salvage or Reconstructed/Theft Recovery (Including history)***	2 Days*	2 Days*
State, providence or other governing locality -issued VIN plates	2 Days*	2 Days*
Gray Market Vehicles or Illegally Imported (as defined in Section VI & VII***)	2 Days*	2 Days*
Insurance and/or Salvage titles (Including history)***	2 Days*	2 Days*
Vehicles being sold with a CO, MSO, or repo affidavit title (if required by state, providence or other governing locality law)	7 Days After Receipt of Title	7 Days After Receipt of Title
Vehicles being sold with no title (Bill of Sale only)	7 Days	7 Days
Any state, providence or other governing locality required damage disclosure	7 Days After Receipt of Title 7 Days	7 Days After Receipt of Title 7 Days
<p>* All arbitration must be initiated within 2 days of Buying dealer's verified receipt of the vehicle, not to exceed 10 days from purchase.</p> <p>** Must announce defects that are \$500 or more to repair.</p> <p>***These issues can be 100% unwound if arbitrated within 2 days.</p>		

Arbitrations initiated on day 3 & beyond will be addressed via the depreciation formula described in Section VI. (Title/Extended Arbitration Policy Section)		
--	--	--

VI. Title Arbitration Policy

1. The Seller guarantees the title of vehicles that are sold through the Auction (non-Title Attached or T/A). This guarantee of the title warrants that title shall be marketable and free and clear of all liens and encumbrances, including any brand (such as 'salvage') noted upon the current or any prior certificate of title unless such encumbrances were announced at the time the vehicle is sold through the Auction and for a period of four (4) years from the date of the transaction. The Auction's liability under this title guarantee shall never exceed the sales price of the vehicle, and this maximum amount shall be reduced by two percent (2%) per month following the transaction date. All liability under this title guarantee shall expire and terminate 48 months after the transaction date. The Auction will not be responsible for any expenses incurred on vehicles returned for late title.
2. All titles submitted by Seller must be in Seller's company name on title or on reassignment form.
3. Clerical Error – If the title problem is due to a clerical or coding error, or incomplete documentation, the Auction shall be given reasonable time after receiving notice to have the error corrected.
4. Procedure – Whenever any claim is made by any person against the title of a vehicle, whether by suit or otherwise, the Buyer, after becoming aware of said claim, shall immediately notify the Auction giving full particulars of the claim, and shall cooperate fully in defending any legal action and in taking other steps to minimize possible loss.
5. The Buyer shall not surrender possession of the vehicle, except as required by legal process, to any claimant, nor shall Buyer voluntarily pay or acknowledge the validity of any claim, without the prior approval of the Auction. Time is of the essence. Any failure on the part of the Buyer to notify the Auction of any claim in a timely manner or failure of the Buyer to cooperate in defending any such claim shall relieve the Auction of any liability under this policy.
6. Seller and Buyer agree that the Auction is neither responsible for odometer mileage on the consigned vehicle nor the information contained in the odometer mileage statement and the damage disclosure statement which Seller as Transferor is required to complete and sign, and Buyer as Transferee is required to acknowledge.
7. In regard to defect in title, and any matter relating to odometer mileage, odometer statements, or damage disclosure statements: Seller and Buyer agree to indemnify and hold harmless the Auction from any liability, loss cost, damage or expense, including attorney fees which may arise either directly or indirectly from the transaction and purchase of the consigned vehicle including but not limited to title services provided.
8. Any sale without proper documents is subject to rejection.

9. Title must be reassigned directly to Buyer. No title assigned directly to the Auction will be accepted.
10. Non-titled vehicles – Auction accepts no responsibility for non-titled vehicles sold without title. Seller must announce the vehicle being sold with a bill of sale only and that there is no title to transfer.
11. All non-titled vehicles and equipment will be sold “AS-IS”.
12. SELLER will NOT be paid for vehicles until a transferable title is received.
13. SELLER will NOT be paid for vehicles in arbitration unless or until arbitration is settled, and vehicles are sold.
14. Foreign titles or titles assigned to foreign dealers, are unacceptable.
15. Seller’s Title Guarantee: The Seller warrants, represents and guarantees that he has and will convey a certificate of title, properly executed, valid in the state, providence or other governing locality where the transaction is occurring and clear of all liens and encumbrances (except current year DMV fees in California), and that he will warrant and defend the title against the claims and demands of all persons whatsoever.
16. Applications for duplicate title will not be accepted (unless announced as such or if state, providence or other governing locality allows).
17. The maximum number of calendar days for title to be received by the auction is determined by the Auction. Refer to the Auction’s Arbitration Policy for their specific deadline.[Sale day is day one (1)].
18. After (_____ Auction Choice) calendar day period, it is the Buyer’s option to return the vehicle or to wait a reasonable period of time for the title.
19. Anyone not having a properly assigned title or reassignment to transfer a title at time of sale must sell “Title Attached/Title Unavailable/Title Absent”.
20. Vehicles lacking lien release must be sold “Title Attached/Title Unavailable/Title Absent”.
21. Any vehicle that is on an MSO (Manufacturer Statement of Origin) must be announced.
22. The Buyer is cautioned not to sell or make repairs on the vehicle until title is received. If title has been mailed from the Auction to Buyer, Buyer may not return vehicle. Buyer is required to notify The Auction one (1) business day before returning vehicles. If a valid negotiable title is presented within the 1-business day notice period, the transaction will stand.
23. Just because a vehicle is returned to the Auction does not mean the Buyer is out of the deal. The vehicle must be received and inspected by the Auction management or designee before the Buyer is out of the deal. Any vehicle returned must be in the same or better condition as when sold.
24. Any and all “Title Brands” which may affect a vehicle’s value must be announced. Some “Title Brands” Include, but are not limited to: Lemon Law, Rental/For Hire, Reconstructed, Stolen Vehicle and Insurance transfers.
25. Seller will be responsible for the buy fee plus reasonable transportation expenses to and from the Buyer’s dealership to the Auction on vehicles returned for “no title”.
26. There may be a charge for excessive mileage on a returned vehicle (at the sole discretion of the Auction).

27. Titles received after the maximum defined in the Auction Policy "Auction Choice" may be subject to a late title fee. All expenses to obtain the title will be charged to the Seller.
28. The Auction will not be responsible for titles mailed from the Auction and not received. Buyer has the choice of alternative delivery method and will pay Auction cost.

VII. Gray Market Vehicles – Policy for Vehicles sold at United State Facilitation Location Providers

1. Only vehicles made in North America for Canadian use and properly converted to U.S. specifications can be sold via a Auction located in the United States and must be announced as such. No other Gray Market vehicles are accepted for sale.
2. Sellers must inform the U.S. Auction that a vehicle has Canadian history at time of registration and must disclose such to the Buyer in writing as an announced condition on the block ticket unless the car is five (5) years old or older (see item 7below).
3. If a vehicle was manufactured in Canada for the Canadian Market, the Manufacturer is required to obtain and affix a U.S. Safety Standard Certification Label if sold via Auction located in the United States to the vehicle.
4. All other vehicles imported from Canada to the U.S. must be imported through a Registered Importer. Registered Importers are required to post a bond with the U.S. Department of Transportation. All vehicles imported through a Registered Importer must have: a. U.S. Safety Standard Certification Label that identifies the Registered Importer. b. Valid U.S. Title
5. All Canadian vehicles offered via a Auction located in the United States, whether imported by a Manufacturer or a Registered Importer, must show miles per hour on the speedometer and miles traveled on the odometer. Title 49, United States Code, Chapter 327, Section 32704, allows replacement of odometers without a doorframe sticker if the conversion from kilometers to miles can be done without changing the distance traveled by the vehicle; therefore, replacement of an odometer under these circumstances does not have to be announced by the Seller.
6. Previous Canadian vehicles that are calendar year and up to 4 years old **MUST BE ANNOUNCED** when sold via a Auction located in the United States.
7. "Gray Market Vehicles" will not be accepted for sale via a Auction located in the United States unless they meet ALL Federal D.O.T./E.P.A Mandated Guidelines (or other applicable national guidelines). Documentation must be provided. Sellers will not offer for sale any European vehicles.
8. Unannounced PREVIOUS CANADIAN vehicles must be reported within seven (7) days of purchase when sold via a Auction located in the United States.

VIII. **Vehicles Admissible For Canada From The United States Policy for Canadian Buyers and/or Sellers**

CANADIAN DEALERS – Please refer to the link following for a list of vehicles admissible from the United States - <http://www.tc.gc.ca/roadsafety/importation/VAFUS/list/VAFUS.pdf>

It is the sole responsibility of the Seller/Buyer to review and adhere to any and all restrictions and requirements related to the importation and/or sale of vehicles referred to in the above link.

1. Vehicles admissible from the United States into Canada and properly converted to Canadian specifications can be sold via a Auction located in Canada and must be announced as a United States origin vehicle.
2. Sellers must inform the Canadian Auction that a vehicle has United States history at time of registration and must disclose such to the Buyer in writing as an announced condition on the block ticket.
3. All other vehicles imported from the United States to Canada must be imported through the Registrar of Imported Vehicles (www.riv.ca) and conform to any and all applicable requirements.
4. All United States vehicles offered via a Auction in Canada, whether imported by a Manufacturer or the Registrar of Imported Vehicles (www.riv.ca), must show miles or km per hour on the speedometer and miles or km traveled on the odometer, and disclosed accordingly.
5. United States origin vehicles will not be accepted for sale via a Auction in Canada unless they meet ALL Federal importation requirements and provide all necessary documentation.

Unannounced PREVIOUS UNITED STATES vehicles must be reported within seven (7) days of purchase when sold via a Auction located in Canada

Structural Damage Policy – OVE.com/Simulcast has adopted the NAAA Structural Damage Policy

1. Sellers Disclosure Requirements - Seller must disclose structural damage, repairs or replacements as outlined in this policy prior to selling a vehicle at auction. The recommended declarations are:

A. Structural Damage - The vehicle has structural damage and/or repairs and will not be subject to arbitration under this policy.

B. Certified Structural Repairs - The vehicle has sustained damage to a specifically identified structural component, which has been repaired, and the vehicle has been certified to be within the Used Vehicle Measurement Standard (UVMS). The vehicle, if properly announced, may be arbitrated only for improper repair of the designated area, existing damage or repairs to other areas, or failure to be within the UVMS (see par. 3).

C. Structural Alteration - The vehicle has an altered frame or unibody as specifically announced. The vehicle can be arbitrated only for damage or repairs to structural components other than those disclosed or in the event of improper alteration. Such a disclosure should be made for the following alterations, unless they are clearly obvious by the appearance of the vehicle.

- Frame lengthened or shortened.
- Suspension altered.
- After market accessories installed/removed.

2. Seller's Disclosure Not Required - No declaration will be required for existing insignificant damage or repair thereof. Insignificant damage is defined as:

- Damage due to transport tie-down if less than 1", improper jacking or lifting or contact with parking abutments and/or road debris, provided that the vehicle is within the UVMS.

3. Measurement of Vehicle - Selling auction will, at its discretion, have a vehicle measured at a facility of its choice. Prior to measurement a vehicle must first visually indicate a physical condition to warrant the measurement. Purchaser will agree to pay for this measurement if the vehicle is within the UVMS. Seller will be responsible for charges if the vehicle is found to be beyond the UVMS.

4. Used Vehicle Measurement Standard - For purposes of arbitration under this policy the Used Vehicle Measurement Standard (UVMS) specifications are:

A. The vehicle will measure to a total tolerance of no more than +/- 8mm of published specifications in length, width and height at all master control points; and

B. Symmetrically (comparative measure from side to side and point to point) the length, width and height must measure to a tolerance of no more than 6mm. In each case the fender to door, door to door, and/or door to quarter panel gaps must indicate proper fit of the panels.

5. Undisclosed Structural Damage or Repair - A vehicle may be arbitrated if it has undisclosed existing or repaired damage, which should have been disclosed under this policy, even though the vehicle is within the UVMS.

6. Arbitration Period - Buyer must arbitrate improperly disclosed structural damage within 7 calendar days from date of purchase. The vehicle must be returned to the selling auction, or to an auction or facility designated by the auction within 7 calendar days of arbitration.

7. Buyer's Reimbursement by Seller - In the event of improperly disclosed structural damage the Seller will be responsible to reimburse the Buyer for:

A. The actual price of the vehicle,

B. The Buyer's fee,

C. Measurement and arbitration fees incurred at the auction, and

D. Reasonable transportation costs actually incurred transporting the vehicle to and from the Buyer's dealership.

E. Post-sale inspection fees remain the responsibility of the buyer.

8. Structural Damage Policy Clarifying Points

A. Towing packages do not require announcement.

B. Access holes for Paintless Dent Removal do not require announcement if 1/4" or smaller.

Many PDR access holes in very close proximity or access holes greater than 1/4" need to be assessed on a case by case basis. Has the structural integrity of the vehicle been compromised?

C. Damaged or replaced core supports are not arbitrable under this policy. Damage to the apron on a unibody in the area where the core support attaches may be arbitrable if significant damage or distortion has occurred. Will the unibody measure within the UVMS?

D. Welded exhaust hangers are not arbitrable under this policy.

E. Floor/trunk panels dented to a depth of 2" or more constitute structural damage and must be disclosed. Tears in these panels that separate welds, rivets or other bonds also must be disclosed.

F. Roofs that have been re-skinned do not require disclosure. Roofs that have been cut off or removed and repaired must be disclosed.

G. Quarter panel, rocker panel, floor pan, etc. damage to a ladder or perimeter frame vehicle is not structural damage and does not require disclosure.

Frame Identification	
Unibody	
<ul style="list-style-type: none"> • Strut towers will be present • Rails and floor welded together • No independent rail system • Aprons will be present • Core support typically welded to aprons 	
Unibody on Frame	
<ul style="list-style-type: none"> • Unibody bolts to frame • Rails independently bolted to suspension and drive train • Has aprons • No strut towers • Rails tend to be a thicker gauge metal (iron) • Core support is typically welded to aprons 	
Conventional Frame	
<ul style="list-style-type: none"> • Body is not welded to frame • Rails independently bolted to suspension and drive train • No aprons • No strut towers • Rails tend to be a thicker gauge metal (iron) • Core support is typically mounted by bolts only 	

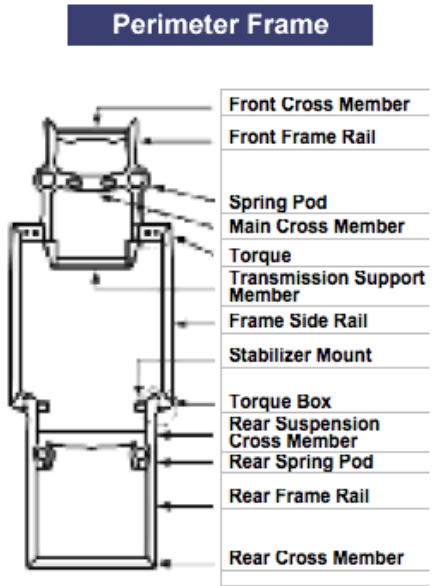

Component	Disclosure Requirement		
	Unibody	Unibody on Frame	Conventional Frame
Radiator Core Support (Including the upper & lower tie bars, center support or side baffles)		NONE	
Frame Rail Extensions [Ears] (On conventional frame vehicles located at the end of the rail to which the bumper, reinforcement or isolator attach)		NONE	
Frame Rails (Including front, center, & rear rails)	Existing, repaired damage or replacement		
Spring Pod, Torque Box or Stabilizer Mount	N/A	Existing, repaired damage or replacement	
Cross members (Except bolt-on)	N/A	Existing, repaired damage or replacement	
Apron/Upper Reinforcement Rails	Existing, repaired damage or replacement		NONE
Strut Tower	Existing, repaired damage or replacement		NONE
Cowl Panel/Firewall (Excluding cowl vent panel)	Existing, repaired damage or replacement		NONE
Support Pillars (A, B, C or D Pillars)	Existing, repaired damage or replacement		
Roof	Replacement		
Rocker Panel (Outer)	Replacement		NONE
Rocker Panel (Inner)	Existing, repaired damage or replacement		NONE
Floor Panels	Torn and/or perforated if 1" or more, dented if deflected more than 2" or replacement floor panel		NONE
Quarter or Cab Panel	Replacement		NONE
Rear Body Panel	NONE		

